

Second Day in Computer Class

Paint

What is paint?

Paint is a create drawing on a blank drawing area. Many of the tools in paint use for create drawing.

How to start Paint in Computer?

- Click Start Button
- Click All program
- Click Accessories
- Click Paint

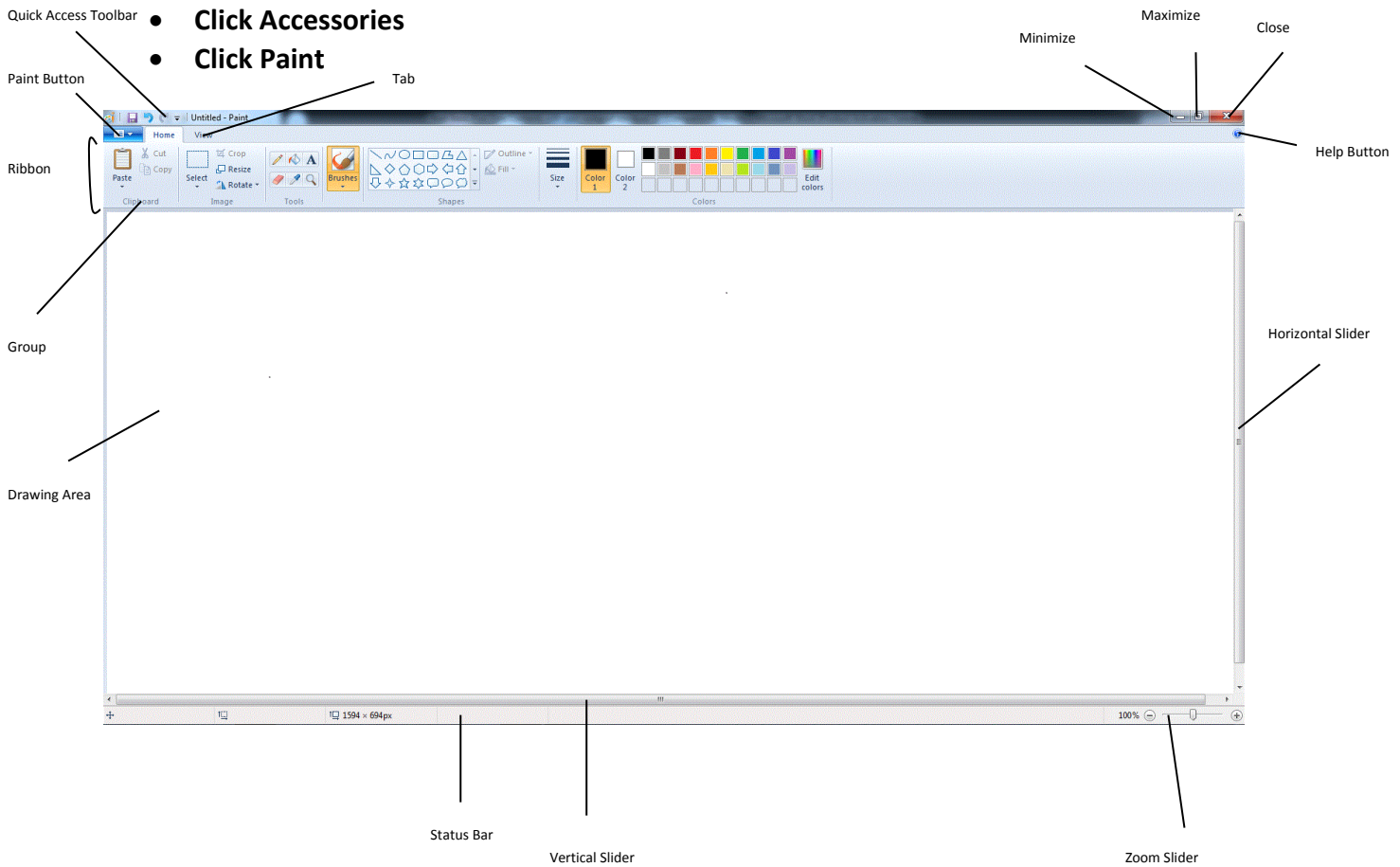

Second Day in Computer Class

Home Tab

Home

Pencil Tool

Use the pencil tool create straight line of curve line.



Straight Line



Curve Line

Fill with color

Its use to fill the color any shape or picture

Eraser

Erase any picture or shape

Line Tool

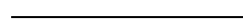
Create straight line 

Curve Tool

Create curve line but use to three steps 

Make this design

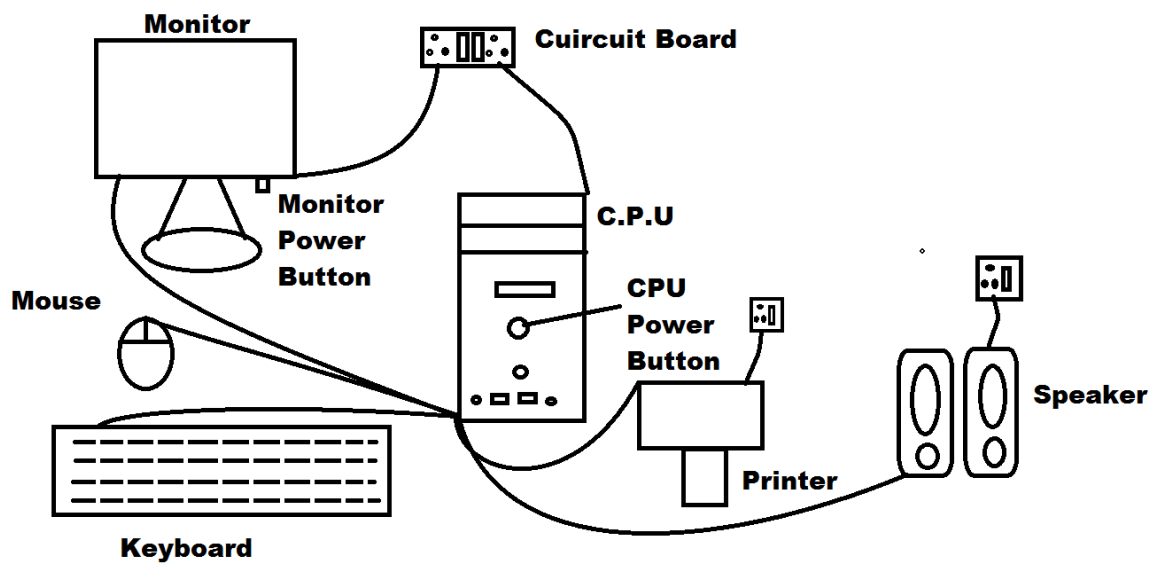

Second Day in Computer Class

Undo 

Go to Backward.

Redo 

Go to forward.

Brush Tool 

Brush Tool use to create straight line or curve but that have a different texture. By using different – different brushes

Use the brush tool

- Click Brush Button
- Choose you want to

Polygon Tool 

Its use to draw custom shape

Color Picker 

Copy color another shape or picture

Text Tool 

Text tool use to type text in your picture

Select 

Select text or picture for editing or change color.

Shapes 

Create new shapes for ex. Square, Circle, Triangle, Star, Heart, and Arrow.

For Ex. 

Second Day in Computer Class

Make This Design

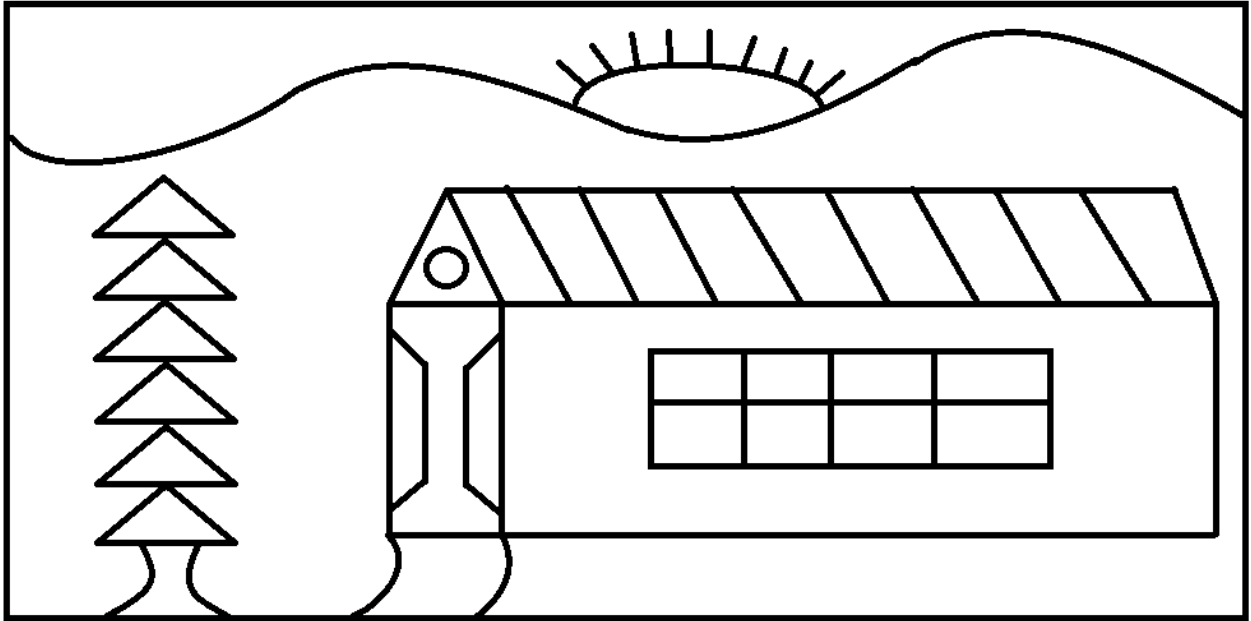

Second Day in Computer Class

Paint Button

1) New

- Create a new page
 - Click Paint Button
 - Click New

2) Open

- Open an existing picture
 - Click Paint Button
 - Click open
 - Find your picture
 - Click Open

3) Save

- Save a new document or picture.
 - Click Paint Button
 - Click Save
 - Find your Location
 - Enter File Name
 - Click Save

4) Save As

-
- Click Paint Button
- Click Save As
- Find your Location
- Enter File Name
- Save

5) Print

- Click Paint Button
- Click Print
- Select Printer
- Click Print

Second Day in Computer Class

- 6) Print Preview  **Print preview**
Preview and make changes before printing.

- See your document or picture before printing
 - Click Menu
 - Click Print
 - Click Print preview
 - See your picture before printing

- 7) Print Setup  **Page setup**
Change the layout of the picture.

- Set page margin
 - Top
 - Bottom
 - Left
 - Right

- 8) Set as desktop background  **Set as desktop background**

- Set your picture in desktop background.
 - Click Paint Button
 - Click save
 - Click set as desktop background

- 9) Properties  **Properties**

- Set drawing area page width and height
 - Click paint button
 - Click properties
 - Enter width and height
 - Click Ok

- 10) Exit / Close  **Exit**

- Close your document after save

Clipboard Group

Cut, Copy, Paste

- 1) For Moving 

- Select Text or Picture
- Click Cut
- Go to place where you want to move
- Click Paste

Second Day in Computer Class

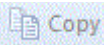
- 2) For Copying 
- Select Text or picture
 - Click Copy
 - Go to place where you want to copy
 - Click Paste

View Tab 

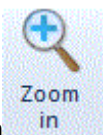
- 1) Zoom in 
- Big size your picture

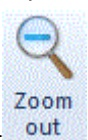
- 2) Zoom Out 
- Small Size your picture

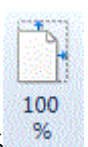
- 3) 100% 
- Actual size your picture

Rulers 

Show set your margin from the page setup

- Show Rulers
 - Click ruler check box
- Hide rulers
 - Click ruler check box

Status Bar 

Show or hide zoom slider and give the details page width and height

Full Screen 

Full screen your picture after click